

GXT pumps can operate at a maximum pressure of 280 bar, flow rates up to 165 lpm, and with water temperatures up to 65°C (149F). This model is suitable for fitting on gantry-style washing systems for heavy goods vehicles, on large vehicles for municipal cleaning services, or misting systems or fire extinguishing systems, where its superior flow rate performance is beneficial.

Le pompe della serie GXT possono lavorare ad una pressione massima di 280 bar, una portata fino a 165lpm, ed una temperatura dell'acqua fino a 65° (149 F).

Questo modello si adatta per essere montato su portali di lavaggio per mezzi pesanti, su veicoli di grossa taglia per servizi di pulizia municipale o ancora per impianti di nebulizzazione o per sistemi anticendio, sfruttando soprattutto l'elevata performance di portata.



GXT Pumps family / Famiglia pompe



GXT - H

Part. No. Codice	Part. No. Codice	Flow Rate / Portata				Max Pressure Pressione massima		RPM Giri /Minuto		Max Power / Potenza Massima				Power take-off Presa di forza
		l/min		US GPM		Bar	Psi	50 Hz	60 Hz	HP		Kw		
		50 Hz	60 Hz	50 Hz	60 Hz					50 Hz	60 Hz	50 Hz	60 Hz	
GXT8020SL	1.099-207.0	80	96	20.9	25.1	200	2900			41.1	49.3	30.2	36.2	◁40
GXT8020SR	1.099-208.0	80	96	20.9	25.1	200	2900			41.1	49.3	30.2	36.2	40▷
GXT1020SL	1.099-209.0	100	120	25.8	31.0	200	2900			51.3	64.6	37.7	45.4	◁40
GXT1020SR	1.099-210.0	100	120	25.8	31.0	200	2900			51.3	64.6	37.7	45.4	40▷
GXT1215SL	1.099-211.0	120	144	31.3	37.6	150	2175	1000	1200	47.0	56.4	34.6	41.5	◁40
GXT1215SR	1.099-212.0	120	144	31.3	37.6	150	2175			47.0	56.4	34.6	41.5	40▷
GXT1515SL	1.099-213.0	150	180	39.2	47.0	150	2175			59.0	70.8	43.4	52.1	◁40
GXT1515SR	1.099-214.0	150	180	39.2	47.0	150	2175			59.0	70.8	43.4	52.1	40▷
GXT1712SL	1.099-215.0	170	204	45.0	54.0	120	1740			52.4	62.9	38.6	46.3	◁40
GXT1712SR	1.099-216.0	170	204	45.0	54.0	120	1740			52.4	62.9	38.6	46.3	40▷

P.T.O. Reference guide / Legenda prese di forza

Single P.T.O. Ø 40 mm Left
Singola presa di forza Ø 40 mm Sinistra **◁40**

Single P.T.O. Ø 40 mm Right
Singola presa di forza Ø 40 mm Destra **40▷**

The flow rate values may vary by ± 5% compared to the production label values.
I valori di portata possono discostarsi del ± 5% rispetto i valori di targa.

Weight / Peso	Kg	67.5
Oil capacity / Capacità olio	lt.	5.5
Inlet / Entrata	G	1 1/2"
Outlet / Uscita	G	1"

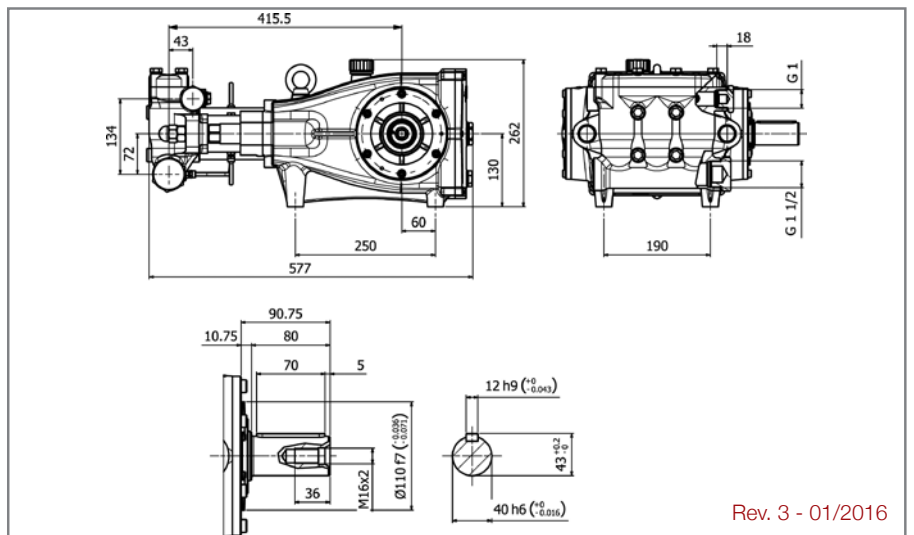

Rev. 3 - 01/2016

